



**NONRESIDENT
TRAINING
COURSE**

October 1994



Sound-Powered Telephone Talkers' Training Manual

NAVEDTRA 14232

Although the words "he," "him," and "his" are used sparingly in this course to enhance communication, they are not intended to be gender driven or to affront or discriminate against anyone.

PREFACE

By enrolling in this self-study course, you have demonstrated a desire to improve yourself and the Navy. Remember, however, this self-study course is only one part of the total Navy training program. Practical experience, schools, selected reading, and your desire to succeed are also necessary to successfully round out a fully meaningful training program.

THE COURSE: This self-study course is organized into subject matter areas, each containing learning objectives to help you determine what you should learn along with text and illustrations to help you understand the information. The subject matter reflects day-to-day requirements and experiences of personnel in the rating or skill area. It also reflects guidance provided by Enlisted Community Managers (ECMs) and other senior personnel, technical references, instructions, etc., and either the occupational or naval standards, which are listed in the *Manual of Navy Enlisted Manpower Personnel Classifications and Occupational Standards*, NAVPERS 18068.

THE QUESTIONS: The questions that appear in this course are designed to help you understand the material in the text.

VALUE: In completing this course, you will improve your military and professional knowledge. Importantly, it can also help you study for the Navy-wide advancement in rate examination. If you are studying and discover a reference in the text to another publication for further information, look it up.

*1994 Edition Prepared by
QMC(SW) J. G. Pearce Durrance*

Published by
NAVAL EDUCATION AND TRAINING
PROFESSIONAL DEVELOPMENT
AND TECHNOLOGY CENTER

**NAVSUP Logistics Tracking Number
0504-LP-026-8700**

Sailor's Creed

"I am a United States Sailor.

I will support and defend the Constitution of the United States of America and I will obey the orders of those appointed over me.

I represent the fighting spirit of the Navy and those who have gone before me to defend freedom and democracy around the world.

I proudly serve my country's Navy combat team with honor, courage and commitment.

I am committed to excellence and the fair treatment of all."

CONTENTS

CHAPTER	Page
1. Introduction to Sound-Powered Telephones	1-1
2. Sound-Powered Telephone Talker Procedures	2-1
3. The Sound-Powered Telephone System	3-1
4. Sound-Powered Telephone Exercises	4-1
APPENDIX	
I. References Used To Develop This TRAMAN	AI-1

INSTRUCTIONS FOR TAKING THE COURSE

ASSIGNMENTS

The text pages that you are to study are listed at the beginning of each assignment. Study these pages carefully before attempting to answer the questions. Pay close attention to tables and illustrations and read the learning objectives. The learning objectives state what you should be able to do after studying the material. Answering the questions correctly helps you accomplish the objectives.

SELECTING YOUR ANSWERS

Read each question carefully, then select the BEST answer. You may refer freely to the text. The answers must be the result of your own work and decisions. You are prohibited from referring to or copying the answers of others and from giving answers to anyone else taking the course.

SUBMITTING YOUR ASSIGNMENTS

To have your assignments graded, you must be enrolled in the course with the Nonresident Training Course Administration Branch at the Naval Education and Training Professional Development and Technology Center (NETPDTC). Following enrollment, there are two ways of having your assignments graded: (1) use the Internet to submit your assignments as you complete them, or (2) send all the assignments at one time by mail to NETPDTC.

Grading on the Internet: Advantages to Internet grading are:

- you may submit your answers as soon as you complete an assignment, and
- you get your results faster; usually by the next working day (approximately 24 hours).

In addition to receiving grade results for each assignment, you will receive course completion confirmation once you have completed all the

assignments. To submit your assignment answers via the Internet, go to:

<http://courses.cnet.navy.mil>

Grading by Mail: When you submit answer sheets by mail, send all of your assignments at one time. Do NOT submit individual answer sheets for grading. Mail all of your assignments in an envelope, which you either provide yourself or obtain from your nearest Educational Services Officer (ESO). Submit answer sheets to:

COMMANDING OFFICER
NETPDTC N331
6490 SAUFLEY FIELD ROAD
PENSACOLA FL 32559-5000

Answer Sheets: All courses include one “scannable” answer sheet for each assignment. These answer sheets are preprinted with your SSN, name, assignment number, and course number. Explanations for completing the answer sheets are on the answer sheet.

Do not use answer sheet reproductions: Use only the original answer sheets that we provide—reproductions will not work with our scanning equipment and cannot be processed.

Follow the instructions for marking your answers on the answer sheet. Be sure that blocks 1, 2, and 3 are filled in correctly. This information is necessary for your course to be properly processed and for you to receive credit for your work.

COMPLETION TIME

Courses must be completed within 12 months from the date of enrollment. This includes time required to resubmit failed assignments.

PASS/FAIL ASSIGNMENT PROCEDURES

If your overall course score is 3.2 or higher, you will pass the course and will not be required to resubmit assignments. Once your assignments have been graded you will receive course completion confirmation.

If you receive less than a 3.2 on any assignment and your overall course score is below 3.2, you will be given the opportunity to resubmit failed assignments. **You may resubmit failed assignments only once.** Internet students will receive notification when they have failed an assignment--they may then resubmit failed assignments on the web site. Internet students may view and print results for failed assignments from the web site. Students who submit by mail will receive a failing result letter and a new answer sheet for resubmission of each failed assignment.

COMPLETION CONFIRMATION

After successfully completing this course, you will receive a letter of completion.

ERRATA

Errata are used to correct minor errors or delete obsolete information in a course. Errata may also be used to provide instructions to the student. If a course has an errata, it will be included as the first page(s) after the front cover. Errata for all courses can be accessed and viewed/downloaded at:

<http://www.advancement.cnet.navy.mil>

STUDENT FEEDBACK QUESTIONS

We value your suggestions, questions, and criticisms on our courses. If you would like to communicate with us regarding this course, we encourage you, if possible, to use e-mail. If you write or fax, please use a copy of the Student Comment form that follows this page.

For subject matter questions:

E-mail: n314.products@cnet.navy.mil
Phone: Comm: (850) 452-1001 ext. 1754
DSN: 922-1001 ext. 1754
FAX: (850) 452-1370
(Do not fax answer sheets.)
Address: COMMANDING OFFICER
NETPDTC (CODE 314)
6490 SAUFLEY FIELD ROAD
PENSACOLA FL 32509-5237

For enrollment, shipping, grading, or completion letter questions

E-mail: fleetservices@cnet.navy.mil
Phone: Toll Free: 877-264-8583
Comm: (850) 452-1511/1181/1859
DSN: 922-1511/1181/1859
FAX: (850) 452-1370
(Do not fax answer sheets.)
Address: COMMANDING OFFICER
NETPDTC (CODE N331)
6490 SAUFLEY FIELD ROAD
PENSACOLA FL 32559-5000

NAVAL RESERVE RETIREMENT CREDIT

If you are a member of the Naval Reserve, you will receive retirement points if you are authorized to receive them under current directives governing retirement of Naval Reserve personnel. For Naval Reserve retirement, this course is evaluated at 2 points. (Refer to *Administrative Procedures for Naval Reservists on Inactive Duty*, BUPERSINST 1001.39, for more information about retirement points.)

COURSE OBJECTIVES

In completing this nonresident training course, you will demonstrate a knowledge of the subject matter by correctly answering questions on the following: operation of sound-powered telephones, telephone-talker procedures, the sound-powered telephone system, and telephone-talkers scenarios and exercises.

Student Comments

Course Title: Sound-Powered Telephone Talkers' Training Manual

NAVEDTRA: 14232 **Date:** _____

We need some information about you:

Rate/Rank and Name: _____ SSN: _____ Command/Unit _____

Street Address: _____ City: _____ State/FPO: _____ Zip _____

Your comments, suggestions, etc.:

<p>Privacy Act Statement: Under authority of Title 5, USC 301, information regarding your military status is requested in processing your comments and in preparing a reply. This information will not be divulged without written authorization to anyone other than those within DOD for official use in determining performance.</p>
--

NETPDTC 1550/41 (Rev 4-00)

CHAPTER 1

INTRODUCTION TO SOUND-POWERED TELEPHONES

LEARNING OBJECTIVES

Learning objectives are stated at the beginning of each chapter. These learning objectives serve as a preview of the information you are expected to learn in the chapter. By successfully completing the nonresident training course (NRTC) for this training manual (TRAMAN), you indicate you have met the objectives and have learned the information.

Upon completing this chapter, you should be able to do the following:

- *Explain the fundamentals of sound-powered telephone communications.*
- *Apply the phonetic alphabet and the Navy's standard pronunciation of numerals.*

OPERATION OF SOUND-POWERED TELEPHONES

Sound-powered telephones are just what the name implies. They are telephones powered by the sound pressure of your voice rather than batteries or an electrical power source. If your phones work properly, speaking in a strong, clear voice generates enough current to carry your voice to all other phones on the circuit.

When you speak into the mouthpiece, the sound waves of your voice cause a diaphragm to vibrate. The vibrations are transferred from the diaphragm through a drive rod to an armature centered in a wire coil. The current then is transmitted to a receiver (the earpiece), where the process is reversed. The person at the other end of the circuit hears the sounds you transmitted.

The earpiece, though shaped differently from the mouthpiece, also contains a diaphragm, an armature, and a coil. The earpiece and the mouthpiece can be used interchangeably; you can talk into the earpiece or hear through the mouthpiece. This feature is important to remember should a failure occur in one of the pieces. It is also important because you need to be aware that an earpiece turned away from your head will pick up distracting noises.

- Q1. What is the power source of the sound-powered telephone system?*
- Q2. How do you generate enough current to carry your voice to all other phones in the circuit?*
- Q3. What action should you take if your mouthpiece fails?*

IMPORTANCE OF SOUND-POWERED TELEPHONES

Communications are of vital importance to a shipboard organization. The most important interior communications system used aboard ship is the sound-powered telephone. Without this system to exchange accurate, up-to-date information, the ship would be unable to function properly and achieve its mission.

Can you think of an instance in your past when you were given inaccurate information or you received it too late to be useful? What kind of problems did that cause you? Imagine, then, commanding officers trying to lead their warships during a

battle without a means of receiving or transmitting current, reliable information.

Current, reliable information yields good decisions in both routine and emergency operations. This information must be passed over sound-powered telephone circuits from damage control central, engineering spaces, weapons control, after steering, radio central, lookouts, the combat information center, the signal bridge, and various other stations aboard the ship.

You, as the phone talker, play a vital role that affects the safety of your shipmates and the overall performance of your ship. The timely and efficient exchange of accurate information will happen only if you know your job and execute it to the best of your ability. To do that, you should use standard phrases and common terminology when relaying information; in addition, you should practice the proper care of your phones.

Q4. Why is the sound-powered phone the most important interior communications system aboard ship?

Q5. What kind of information must a commanding officer have to make good decisions during ship operations?

OPERATION OF SOUND-POWERED TELEPHONE CIRCUITS

The operation of a sound-powered telephone circuit involves a message originator, a control station, and anywhere from one to several phone talkers at different stations. Each one plays a distinct role in ensuring messages are transmitted properly.

THE MESSAGE ORIGINATOR

The message originator's choice of words is very important. For example, suppose you are the bridge sea and anchor detail phone talker. The officer of the deck (OOD) tells you to pass the following message: "Find out what gas turbines and diesel generators are in use." The officer of the deck, as the message originator, has used incorrect phraseology. You would have to

rephrase this message before sending it, possibly causing confusion and delay. The OOD should have phrased the message this way: "Main Control – Bridge. What gas turbines and diesel generators are on the line?"

If a message is phrased correctly, all you have to do is repeat it word for word over your phone. Repeating a message word for word also reduces the chance of transmitting the message incorrectly.

If you are originating the message, use correct terminology and phrase the message exactly the way you want it transmitted. If you are relaying the message, keep it as short as possible and ensure clarity by using specific terms.

Q6. Why does the message originator need to phrase the message exactly the way it is to be transmitted?

Q7. As a phone talker, you should transmit a message you receive from the originator in what way?

THE CONTROL STATION

One station on each circuit is designated the control station. It is the duty of the controller to know proper control procedures and to ensure that all stations on the circuit know he or she is the controller. The controller must act as the monitor for all circuit transmissions to enforce existing rules and regulations for good sound-powered telephone communications.

THE PHONE TALKER

Most of this manual discusses the operation of the sound-powered telephone from the standpoint of the phone talker. As a phone talker, you must transmit a message exactly as it is given to you. Therefore, the originator of the message must give you the exact message he or she wishes to transmit. As a phone talker, you should observe the following general rules:

- Always be alert. Pay close attention to the messages transmitted over the phone by the officer or petty officer in charge of the station (message originator). If possible, take notes when other stations on the circuit relay messages to you. Do not engage in idle conversation on the phone. Keep your mind on your assigned duty.
- Test the circuit regularly. A line may malfunction as a result of damage, faulty phones, or other equipment failure. Unless you test the line periodically, you may be unaware of the malfunction and fail to receive an important message.
- Do not use the normal pronunciation of alphabetic letters when speaking over the phone. It is easy to confuse the sounds of certain letters, such as bee and dee or cee and zee. To avoid such confusion, the Navy requires that you use phonetic equivalents of letters instead of the letters themselves. However, you may use the alphabetic pronunciation of abbreviations and acronyms that are easily understood.

Q8. What station is in charge of each circuit?

Q9. Why should you test the circuit periodically?

Q10. Why can't you use alphabetic letters as references?

USE OF THE PHONETIC ALPHABET

The Navy has used a phonetic alphabet for many years. At times, it has changed some of the phonetic equivalents to words that might more quickly bring to mind the letters they represent. The various North Atlantic Treaty Organization (NATO) countries adopted the following phonetic alphabet as a means of overcoming the many language difficulties. Each word is accented on the capitalized syllable.

STANDARD PHONETIC ALPHABET

LETTER	EQUIVALENT	SPOKEN
A	ALFA	AL fah
B	BRAVO	BRAH voh
C	CHARLIE	CHAR lee
D	DELTA	DELL ta
E	ECHO	ECK oh
F	FOXTROT	FOKS trot
G	GOLF	GOLF
H	HOTEL	hoh TELL
I	INDIA	IN dee ah
J	JULIETT	JEW lee ett
K	KILO	KEY loh
L	LIMA	LEE mah
M	MIKE	MIKE
N	NOVEMBER	no VEM ber
O	OSCAR	OSS cah
P	PAPA	pah PAH
Q	QUEBEC	kay BECK
R	ROMEO	ROW me oh
S	SIERRA	see AIR rah
T	TANGO	TANG go
U	UNIFORM	YOU nee form
V	VICTOR	VIK tah

STANDARD PHONETIC ALPHABET		
LETTER	EQUIVALENT	SPOKEN
W	WHISKEY	WISS key
X	XRAY	ECKS ray
Y	YANKEE	YANG key
Z	ZULU	ZOO loo

You should memorize the phonetic alphabet to express individual letters and spell words that might be misunderstood. The Navy's standard pronunciation of numerals (listed in the following section) is used with the phonetic alphabet to correctly enunciate numbers when you are making telephone reports.

PRONUNCIATION OF NUMERALS

In addition to the use of the phonetic alphabet, the Navy has established standard pronunciations for numerals. The following list shows how you should pronounce numerals:

NUMERALS	PRONOUNCED
0	ZERO
1	WUN
2	TOO
3	TREE
4	FO-WER
5	FIFE
6	SIX
7	SEVEN
8	ATE
9	NINER

REPORTING BEARINGS

The direction of an object from your ship is called the bearing. Bearings are measured in degrees clockwise around a circle from 000° to 360°.

The ship's bow is the reference point for relative bearings. For example, a sailboat dead ahead would bear 000°, a lighthouse off the stern would bear 180°, a ship directly off the port beam would bear 270°, and so on.

True or geographic north is the reference point for true bearings; they are read directly from the gyro compass or a gyro repeater.

The magnetic North Pole is the reference point for magnetic bearings; they can be read from the ship's magnetic compass.

Lookouts report objects in degrees of relative bearing. Each bearing consists of three digits, which the lookout speaks digit by digit as follows:

BEARING	SPOKEN AS
015°	ZERO WUN FIFE
039°	ZERO TREE NINER
053°	ZERO FIFE TREE
082°	ZERO ATE TOO
124°	WUN TOO FO-WER
187°	WUN ATE SEVEN
226°	TOO TOO SIX
250°	TOO FIFE ZERO
295°	TOO NINER FIFE
337°	TREE TREE SEVEN

REPORTING RANGES

Ranges (distance in yards) are reported digit by digit, except for exact multiples of hundreds and thousands, as follows. Speak the words *hundred* and *thousand* as you usually would.

YARDS	SPOKEN AS
50	FIFE ZERO
90	NINER ZERO
150	WUN FIFE ZERO
500	FIFE HUNDRED
1500	WUN FIFE HUNDRED
2000	TOO THOUSAND
4350	FO-WER TREE FIFE ZERO
8000	ATE THOUSAND
15000	WUN FIFE THOUSAND
19600	WUN NINER SIX HUNDRED

- Q11. *Why did the armed forces of various NATO countries adopt the phonetic alphabet?*
- Q12. *What do you call the direction of an object from your ship?*
- Q13. *What is the reference point for relative bearings?*
- Q14. *Ranges are spoken digit by digit except for what value(s)?*

REPORTING POSITION ANGLES

An object located in the sky is reported by its bearing and position angle. The position angle of an aircraft is its height in degrees above the horizon as seen from the ship. The horizon is

0°, and directly overhead is 90°. Position angles are reported in one or two digits and spoken as a whole – not digit-by-digit. The words *position angle* are always spoken before the numerals.

POSITION ANGLE	SPOKEN AS
0	POSITION ANGLE ZERO
10	POSITION ANGLE TEN
20	POSITION ANGLE TWENTY
50	POSITION ANGLE FIFTY
75	POSITION ANGLE SEVENTY FIVE
90	POSITION ANGLE NINETY

The following are examples of initial lookout reports that include bearings, ranges, and position angles:

“Bridge – Forward Lookout. Surface contact bearing tree fife zero, ate thousand yards, moving left to right slowly.”

“Bridge – Aft Lookout. F-18 jet fighter bearing wun six zero, position angle ten, moving right to left very rapidly.”

Chapter 21 of *Basic Military Requirements*, NAVEDTRA 12043, and *Lookout Training Handbook*, NAVEDTRA 12968,

cover the duties of a lookout and the reporting of bearings, ranges, and position angles.

Q15. What is the maximum position angle at which you can report an aircraft?

Q16. How would you report an aircraft that is 40 degrees above the horizon?

SUMMARY

As a sound-powered telephone talker, you serve as the central nerve of the ship. Without you and the other phone talkers who send and receive information between the various stations, the ship cannot operate efficiently and safely.

The quality of the information transmitted depends entirely on how well you perform your job. Become familiar with the phone talker rules and procedures discussed in this chapter. Memorize the phonetic alphabet; the pronunciation of numerals; and the reporting procedures for bearings, ranges, and position angles. Make it your goal to be the best phone talker on the ship.

ANSWERS TO EMBEDDED QUESTIONS

- A1. *The sound pressure of your voice.*
- A2. *Speak in a strong, clear voice.*
- A3. *Talk through the earpiece.*
- A4. *It allows an exchange of accurate, up-to-date information that enables the ship to achieve its mission.*
- A5. *Reliable, accurate information.*
- A6. *The phone talker won't have to rephrase the message, which reduces the chance of an unintended meaning being transmitted.*
- A7. *Word for word, exactly as you received it.*
- A8. *The Control Station.*
- A9. *You might miss an important message.*
- A10. *It is easy to confuse the sounds of certain letters.*
- A11. *To overcome many language difficulties.*
- A12. *Bearing.*
- A13. *The ship's bow.*
- A14. *Exact multiples of hundreds and thousands are spoken as you usually would.*
- A15. *90°.*
- A16. *Position angle forty.*

CHAPTER 2

SOUND-POWERED TELEPHONE TALKER PROCEDURES

LEARNING OBJECTIVES

Upon completing this chapter, you should be able to do the following:

- *Describe the proper telephone-talker procedures.*

TELEPHONE TALKERS

As you undoubtedly realize by now, you will stand some form of watch aboard ship as a telephone talker. A ship at sea requires many phone talkers, even during a peacetime cruising watch. In addition to those serving as lookouts, talkers perform duty in spaces such as the bridge, the combat information center, and engine rooms. To be a good sound-powered phone talker, you must learn proper circuit discipline and telephone-talker procedures.

CIRCUIT DISCIPLINE

On the sound-powered telephone system, everyone can talk and listen at once. For that reason, talkers must maintain strict circuit discipline. Otherwise, the circuit could become clogged with private conversation just when someone is trying to transmit an important message.

The rules for circuit discipline are as follows:

- Transmit only official messages.
- Depress the transmitter button only when you are actually transmitting.
- Use only standard words and phrases.

- Do not use slang or profanity on the phone.
- Use correct nautical terms.
- Never interrupt another station unless you need to pass an emergency message.

If you must interrupt a station on the circuit, use the phrase, “Silence on the line.” You as a phone talker are an important link in the interior communications chain; that chain is no stronger than its weakest link. Unauthorized talking means the chain has at least two weak links. Be professional — if someone else on your circuit persists in useless talking, remind the person that the line must be kept clear for official messages. Circuit discipline also means you must never show impatience, anger, or excitement. You must talk slowly, clearly, and precisely. Circuit discipline means self-discipline.

- Q1. *Why must strict circuit discipline be maintained on the circuit?*
- Q2. *When should you depress the transmitter button?*
- Q3. *When can you interrupt another station’s transmission?*
- Q4. *What phrase should you use if you have to interrupt another station?*
- Q5. *What should you do if another person on the circuit persists in useless talking?*

STANDARD TELEPHONE-TALKER PROCEDURES

The standard procedure for relaying a message is divided into three parts:

1. Give the name of the station called.
2. Give the name of the station calling.

3. State the message.

In other words, you call the station for whom you have a message, identify yourself, and send the message without waiting for the receiving station to answer.

When you receive a message, acknowledge (receipt for) it as soon as you understand the message. Repeat it to the sender word for word. For example, you might receive the message “Main Control – Bridge. Shift control of number one bravo gas turbine to the bridge.” Your response should be “Shift control of number one bravo gas turbine to the bridge. Main Control, aye.” Do not use “aye” to answer “yes” to a question; instead, use “affirmative” or some other appropriate reply. Likewise, use “negative” to answer “no.”

When communicating on the sound-powered phone system, use statements instead of direct questions. For example, say “Report the status of number one bravo gas turbine” instead of asking “What is the status of number one bravo gas turbine?” Say “Report the estimated repair time of number one bravo gas turbine” instead of asking “When will number one bravo gas turbine be repaired?”

Do not use slang expressions or locally devised codes. Also do not use abbreviations that may be easily misunderstood, such as GTE and SSDG.

Q6. The standard procedure for relaying a message is divided into what three parts?

Q7. How do you acknowledge receipt of a message?

Q8. Why should you avoid using abbreviations?

Circuit Testing

To find out if telephone stations are manned and ready, the control station conducts a circuit test. The circuit test consists of a phone check of all stations. When making the phone check, the control station says, "All Stations – Control. Phone check."

Each talker then acknowledges in assigned order. On a damage control circuit, responses to the phone check would go like this:

Talker in repair two: "Repair Too, aye."

Talker in repair three: "Repair Tree, aye."

Talker in repair five: "Repair Fife, aye."

Each station responds in order, but waits only a few seconds for the station immediately preceding to acknowledge. For example, if you are the talker in repair three and the talker in repair two does not respond in a few seconds, you acknowledge. Repair two then responds at the end of the check. A circuit test is not complete until every station has answered and all equipment faults have been corrected.

- Q9. How does the control station find out if all stations on a circuit are manned and ready?*
- Q10. What do you do when the station before you does not answer a circuit test?*
- Q11. When is a circuit test considered complete?*

Sending a Message

When you send a message, first call the name of the station you want to communicate with; then identify your own station; and finally, state the message:

"Foc'sle – Bridge. Range to anchorage too thousand yards."

Receiving a Message

When you receive a message, first repeat the message to the sender; then identify yourself; and last, acknowledge the message:

“Range to anchorage two thousand yards. Foc’sle, aye,”

Repeating a Message

When you receive a message that is not clear to you, ask the sender to repeat the message by using the words, “Say again.” For example, the bridge wants the foc’sle to make the anchor ready for letting go. The bridge talker says, “Foc’sle – Bridge. Make the anchor ready for letting go.”

The foc’sle talker, who does not understand the message, should then say, “Bridge- Foc’sle. Say again.”

The bridge then repeats the message.

The foc’sle acknowledges by saying, “Make the anchor ready for letting go. Foc’sle, aye.”

Q12. What do you do if a message is not clear to you?

Spelling

Spell difficult words, using the phonetic alphabet preceded by the prowords (procedural words) “I spell.” Pronounce the word before and after spelling it, for example:

“Enterprise. I spell: ECHO NOVEMBER TANGO ECHO ROMEO PAPA ROMEO INDIA SIERRA ECHO. Enterprise.”

Q13. What prowords are used before you phonetically spell a word?

Temporarily Leaving the Circuit

When you are relieved by another phone talker, you must request permission to change phone talkers:

“Bridge – After Steering. Request permission to change phone talkers.”

If you need to exchange a set of faulty phones for a good set, you must request permission to change phones:

“Bridge – Combat. Request permission to change phones.”

Once you have been given permission to go off the circuit and your relief rejoins the circuit, the new phone talker reports,

“Bridge – Combat. Back on the line.”

Q14. What must you do before leaving the circuit for any reason?

Q15. What is the correct phrase you should use to rejoin the circuit?

Securing From the Circuit

Before securing from the circuit, you must always get permission. For example, the fantail asks, “Bridge – Fantail. Request permission to secure.”

The bridge says, “Request permission to secure. Bridge, aye. Wait.”

The bridge talker gets permission from the OOD for the phone talker on the fantail to secure and then says, “Fantail – Bridge. Secure.”

The fantail talker replies, “Fantail, aye. Going off the line.”

SUMMARY

The Navy has developed and refined circuit discipline and telephone-talker procedures over a period of many years. The objective of the telephone talker is always to pass important information from one station to another with minimum confusion without being misinterpreted. Master the Procedures covered in this chapter to become a reliable communicator on which your command can count.

ANSWERS TO EMBEDDED QUESTIONS

- A1. *To prevent the circuit from becoming clogged with private conversation when someone is trying to transmit an important message.*
- A2. *Only when you are transmitting.*
- A3. *If you have an emergency message that cannot wait.*
- A4. *“Silence on the line.”*
- A5. *Remind the person to keep the line clear for official messages.*
- A6. *(1) Name of the station called, (2) name of the station calling, (3) the message.*
- A7. *Repeat the message word for word, identify your station, and say “aye.”*
- A8. *Abbreviations can easily be misunderstood.*
- A9. *By conducting a phone check of all stations.*
- A10. *Acknowledge the phone check and let the other station come in at the end.*
- A11. *When every station has answered and all faults in equipment have been corrected.*
- A12. *State the phrase, “Say again.”*
- A13. *“I spell.”*
- A14. *Get permission.*
- A15. *“Back on the line.”*

CHAPTER 3

THE SOUND-POWERED TELEPHONE SYSTEM

LEARNING OBJECTIVES

Upon completing this chapter, you should be able to do the following:

- *Explain the use and care of sound-powered telephone equipment.*
- *Describe the different sound-powered phone circuits and how they are designated.*

SOUND-POWERED TELEPHONE EQUIPMENT

As a sound-powered telephone talker, you must be familiar with the use and care of all sound-powered equipment if you are going to be proficient at your job. In addition to headset-chestsets and handsets, sound-powered equipment includes jackboxes, selector switches, and call signal stations.

THE HEADSET-CHESTSET

Sound-powered telephone headset-chestsets (fig. 3-1) are designed for general shipboard use. The mouthpiece (transmitter) is suspended from a yoke attached to a metal chest plate. The earphones (receiver) are connected by an adjustable headband. The mouthpiece and earphones are connected by wire (tinsel cord) from a junction box on the chest plate. The plug cable is also connected into this junction. The jack plug is connected to the other end of the cable.

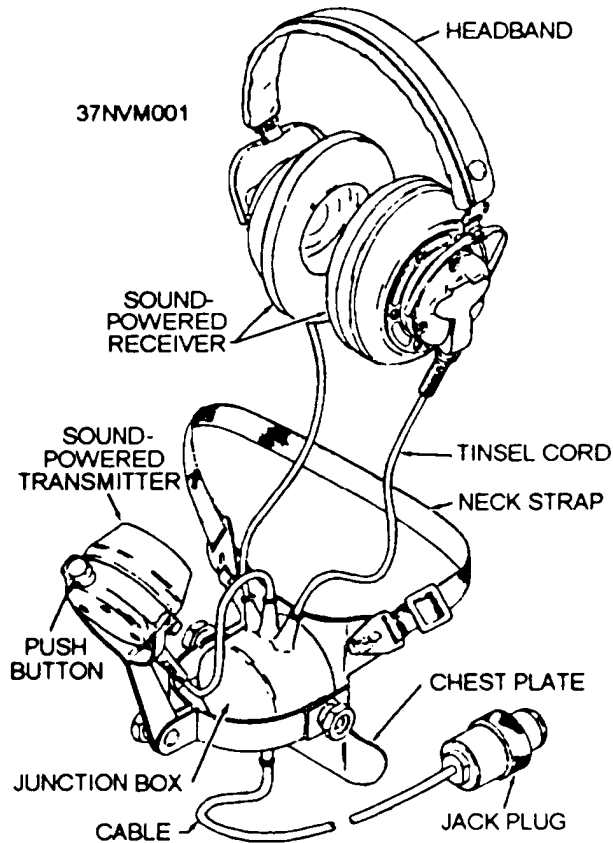

Figure 3-1.-Sound-powered telephone headset-chestset.

Handling the Headset-Chestset

Always handle sound-powered telephone headset-chestsets with care so that they will be working properly if an emergency occurs. When you are not using phones, make them up correctly and stow them in their proper place.

The sets are made as waterproof as possible, but you should not expose them unnecessarily to the weather. Do not drag the cables over sharp edges, pull on them too hard, or allow them to kink. When unplugging the cable from a jackbox, always pull on the body of the plug; never pull on the cable. Figure 3-2 shows a single-gang, sound-powered telephone jackbox.

Q1. What do you do with phones when they are not in use?

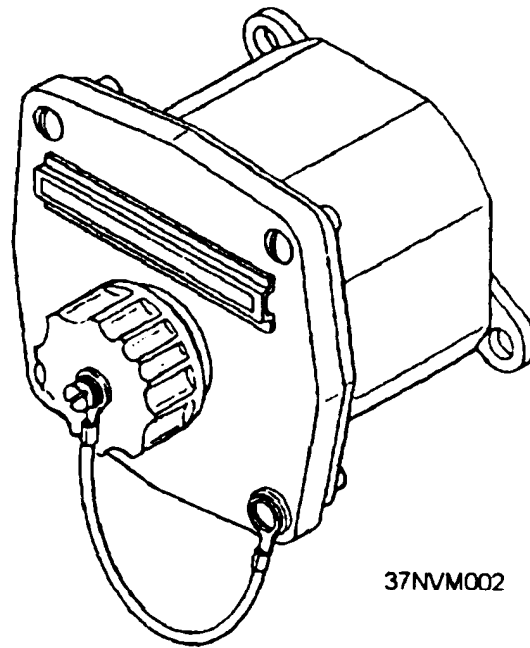

Figure 3-2.-A single-gang sound-powered telephone jackbox.

Donning the Headset-Chestset

When donning the headset-chestset, you should use the following procedure:

1. Remove the set from the stowage hook or stowage box.
2. Hold the set and coiled cable in one hand.
3. Unhook the neck strap and unwind the coiled cable. Do not allow the set to dangle by its connecting wires; this could cause open leads and short out the phones.
4. Put the neck strap around your neck and secure it to the chest plate.
5. Put on the earphones and adjust the ear cushions for maximum comfort and to block out noise.
6. Straighten out any kinks in the connecting wires.

7. Remove the cover on the jackbox and connect the plug into the jack.
8. Test the headset for satisfactory operation. First, get someone to plug another headset into a separate jackbox on the same circuit. You can now conduct a phone check to ensure the phones are operating properly.

Q2. What precaution should you take in unplugging a cable from a jackbox?

Removing and Making Up the Headset-Chestset

To remove and make up a sound-powered telephone headset-chestset, you should use the following procedures:

1. Remove the earphones and hang the headband over the yoke of the transmitter.
2. Remove the plug from the jackbox by holding the plug in one hand and unscrewing the collar with the other. When the collar is loose, grasp the plug and pull it out.
3. Replace the jack cover on the jackbox to keep out moisture and dirt.
4. Lay the cable out on the deck and remove any kinks.
5. Coil up the cable, starting from the end that attaches to the chest plate. Coil with the right hand, making the loops in a clockwise direction. The loops should be about 10 inches across.
6. After the cable is coiled, remove the headband from the transmitter yoke and hold the headband in the same hand with the cable.

7. Fold the transmitter yoke flat so that the mouthpiece lies flush against the chest plate connection box, using care not to pinch the transmitter cable.
8. Hold the headband and cable in the left hand and unhook one end of the neck strap from the chest plate.
9. Bring the top of the chest plate level with the headband and cable. Secure the chest plate in this position by winding the neck strap around the headband and coiled cable just enough times that a short end will be left over. Twist this end once and refasten it to the chest plate. The set is now made up and ready for stowing. Figure 3-3 shows a properly made up sound-powered telephone headset-chestset.

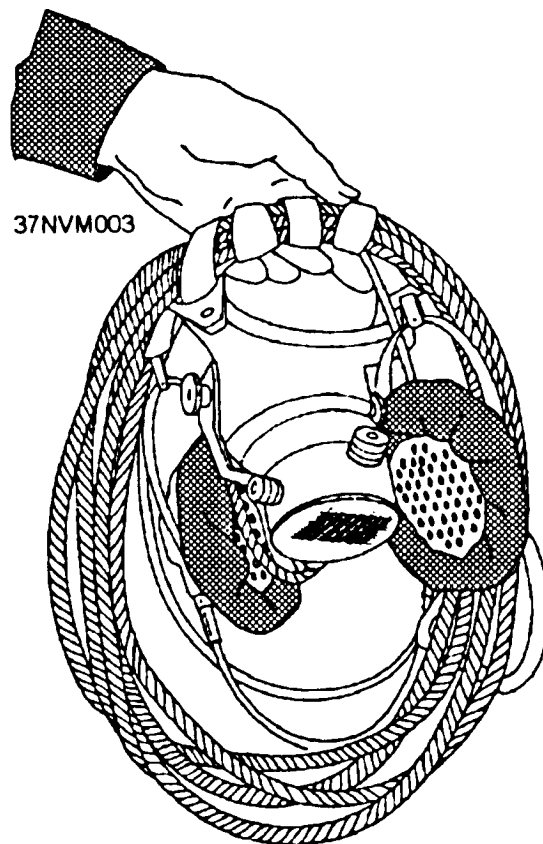

Figure 3-3.-A properly made-up sound-powered telephone headset-chestset.

Stowing the Headset-Chestset

In enclosed spaces, you should stow headset-chestsets on hooks. In machinery spaces and on weather decks, you should stow these sets in stowage boxes, which are designed to stow from one to six sets.

A properly made-up set should fit into its stowage box without your having to force it. Never allow a loose cable to hang out of the box, because it may be damaged when the lid is closed. Never use the stowage box for storing cleaning gear or tools. Cleaning rags give off moisture while chemicals give off fumes that will cause the aluminum diaphragms to rapidly oxidize. Tools and other loose gear may damage the set(s) or may prevent you from getting a set out quickly in an emergency situation.

Q3. Where do you store headset-chestsets located on weather decks and in machinery spaces?

Q4. Why should you never store cleaning gear in a sound-powered phone stowage box?

THE HANDSET

Sound-powered telephone handsets are designed for general use on a line with other handsets or headset-chestsets. You hold the handset in one hand with the receiver over one ear and the transmitter in front of your mouth. You push down the button, located between the transmitter and the receiver, for talking as well as listening.

Sound-powered handsets are hard-wired into sound-powered jackboxes, selector switches, and magneto call stations. For stowage of the handsets, handset holders (fig. 3-4) are installed in enclosed spaces, and handset stowage cabinets are installed at stations exposed to the weather. When you replace the handset in its holder, be sure it is secured so that it cannot fall to the deck and be damaged.

Q5. Why should you replace the handset in its holder and make sure it is secure?

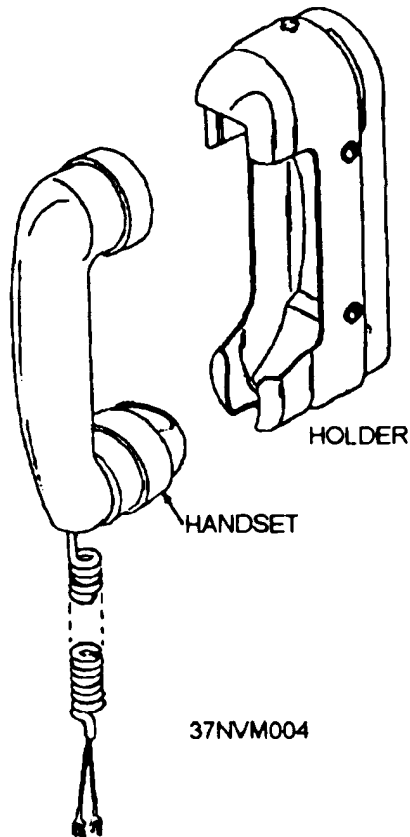

Figure 3-4.-The sound-powered telephone handset and handset holder.

THE SELECTOR SWITCH

Sound-powered telephone selector switches (fig. 3-5) are located throughout the ship at control and operating stations served by more than one sound-powered telephone circuit. The selector switch enables you to talk on any one of several circuits by turning the rotary dial on the switch to the desired circuit. Most of the switches are installed with a sound-powered telephone handset hard-wired into the switch. In areas where a handset is not provided, you must insert a headset-chestset plug into the jack outlet. Selector switches located in normally darkened condition areas are provided with dial illumination.

- Q6. *When talking from a station with a selector switch, how do you shift from one circuit to another?*
- Q7. *Selector switches in darkened-ship condition areas are provided with what special feature?*

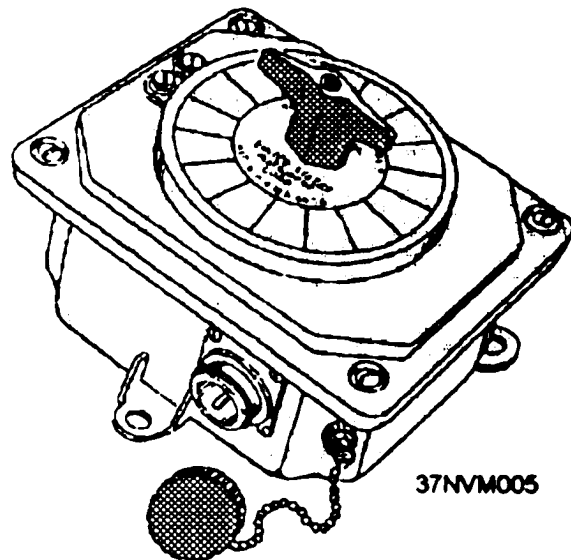

Figure 3-5.-The selector switch.

SOUND-POWERED TELEPHONE CIRCUITS

The sound-powered telephone system consists of individual sound-powered telephone circuits. As stated earlier in chapter 1, each circuit operates without any external source of electrical power. The number and various types of circuits installed depends on the operational requirements of the ship.

TYPES OF CIRCUITS

There are three types of sound-powered telephone circuits: (1) switchboard, (2) switch box, and (3) string. A switchboard circuit originates from a sound-powered telephone switchboard. A switch box circuit originates from a sound-powered switch box. A string circuit consists of a series of telephone station jackboxes connected to a common line.

Q8. From what component does the switchboard circuit originate?

Q9. What components are in a string circuit?

CLASSIFICATION OF CIRCUITS

Sound-powered telephone circuits are divided into three classifications based on their usage: primary, auxiliary, and supplementary.

Q10. What are the three classifications of sound-powered phone circuits?

Primary Circuits

Primary circuits provide communication for primary control and operating functions associated with ship control, weapons control, engineering control, and damage control. Primary circuits are designated by the letters *JA* through *JZ*. (Specific circuit designations are labeled on the front of each jackbox.)

Auxiliary Circuits

Auxiliary circuits duplicate certain principal primary circuits as an alternate means of communication if damage occurs to the primary circuit. The wiring of auxiliary circuits is separated as much as practicable from the wiring of the corresponding primary circuits. Auxiliary circuits have the same letter designation as primary circuits, except they are preceded by the letter *X*. Examples: *XJA*, *X1JV*, and *X1JG*.

Q11. What special precaution has been taken to prevent simultaneous damage to both primary and auxiliary circuits?

Q12. How can you tell the difference between primary and auxiliary circuit designations?

Supplementary Circuits

Supplementary circuits consist of several short, direct circuits, such as those from the bridge to the quarterdeck or from the quarterdeck to the wardroom. Supplementary circuits, designated *X1J* through *X61J*, are normally string circuits. Circuits in

primary and auxiliary systems can be tied together at various switchboards, or individual stations may be cut out of the circuits; but the supplementary system does not have these provisions.

Circuits in the supplementary system are usually not manned. Some supplementary circuits are equipped with a buzzer or a horn for calling another station. The supplementary circuit you will use the most is the call signal station (fig. 3-6). To call another station, you turn the station selector switch to the station you want to call and then turn the hand crank. The hand crank operates a magneto generator that produces a distinctive howl (an audible noise). The howl will continue as long as you crank the generator.

Q13. How do you call another station from a call signal station?

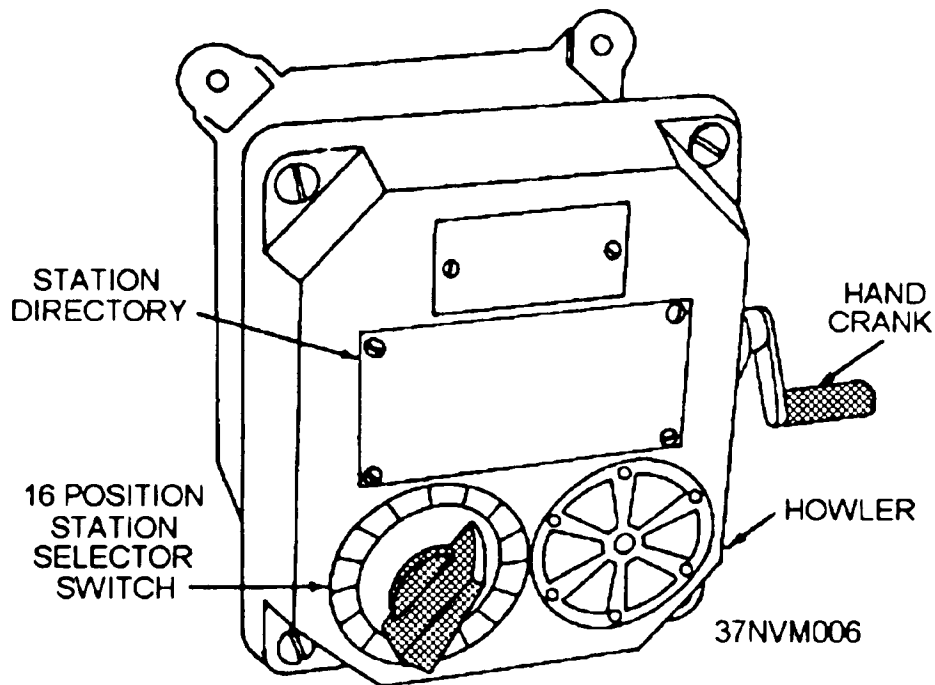

Figure 3-6.-A call signal station.

CIRCUIT DESIGNATIONS

Circuit designations are characterized by a letter and number code. The 21JS4 primary battle circuit, for example, is identified as follows: the numerals 21 indicate the purpose of the circuit; the letter *J* denotes sound power; the letters *S* means general purpose (radar, sonar, and electronic countermeasures [ECM] information); and the numeral 4 indicates a particular station in the circuit. The same circuit in the auxiliary system is X21JS4. All auxiliary and supplementary circuit designations are preceded by the letter X. Supplementary circuits are easily identified as such because they have no letter after the letter *J*.

Q14. What does the letter J mean in sound-powered circuit designations?

Q15. How can you identify a supplementary circuit?

The following are some typical shipboard sound-powered circuit designations:

CIRCUIT DESIGNATION	CIRCUIT TITLE
JA	Captain's battle circuit
1JG	Aircraft control circuit
JL	Lookout circuit
1JS	Combat information center information circuit
21JS	Surface search radar circuit
61JS	Sonar information circuit
1JV	Maneuvering and docking circuit
4JV	Engineering circuit (fuel and stability)
JW	Ship-control bearing circuit
JX	Radio and signals circuit

CIRCUIT DESIGNATION	CIRCUIT TITLE
------------------------	---------------

2JZ	Damage and stability control
4JZ	Forward repair circuit
X1JV	Auxiliary maneuvering and docking circuit
X2JZ	Auxiliary damage and stability control circuit
X1J	Ship's administration circuit
X8J	Replenishment-at-sea circuit

SUMMARY

An emergency on board ship is a real possibility you confront everyday. During emergency and routine evolutions, communications are of vital importance. You should make sure you know how to use your equipment. You should also make sure your equipment is in good shape so that it won't fail you at a critical time.

ANSWERS TO EMBEDDED QUESTIONS

- A1. *Make up the phones correctly and stow them in their proper place.*
- A2. *Always pull on the body of the plug; never on the cable.*
- A3. *In stowage boxes.*
- A4. *Because rags and chemicals give off moisture and fumes that will cause the aluminum diaphragms to rapidly oxidize.*
- A5. *So it cannot fall to the deck and be damaged.*
- A6. *Turn the rotary dial on the switch to the desired circuit.*
- A7. *They are provided with dial illumination.*
- A8. *From a sound-powered telephone switchboard.*
- A9. *A series of telephone station jackboxes connected to a common line.*
- A10. *Primary, auxiliary, and supplementary.*
- A11. *The wiring of the auxiliary circuits is separated as much as practicable from the wiring of the corresponding primary circuits.*
- A12. *Auxiliary circuit designations are preceded by the letter X.*
- A13. *Turn the station selector switch to the station you want to call, and then turn the hand crank.*
- A14. *Sound power.*

A15. The circuit designation has no letter after the letter J.

CHAPTER 4

SOUND-POWERED TELEPHONE EXERCISES

LEARNING OBJECTIVES

Upon completing this chapter, you should be able to do the following:

- *Apply the basic sound-powered telephone talker circuit procedures.*

The following exercises provide some practical training that will improve phone talker skills. These exercises maybe used as part of a phone-talker training program or as practice sessions by individual groups of phone talkers. Each exercise consists of a scenario involving four phone talkers.

Before starting the practice session, run through each scenario several times. After each practice session, evaluate the drill, individually or as a group, so that you can correct any problems. You will be surprised by how much each practice session improves the skills of each phone talker.

To add variety and expand the quality of this training, you can enlarge the scenarios in this manual or develop entirely new ones. You can also record practice sessions and then allow the group to listen to the recording to identify and correct problems.

EXERCISES

Each of the following exercises consists of three parts: (1) a fictitious scenario, (2) a list of the phone talker stations involved in the scenario, and (3) the transmission each phone talker should make. First read the scenario aloud and make sure all phone talkers understand the situation. Then assign each phone talker a role and begin the practice session.

DAMAGE CONTROL EXERCISE

Scenario

The commanding officer has ordered the ship to general quarters soon after a class Alfa fire is reported in compartment 1-116-0-L, the operations berthing compartment. Two crew members who reported the fire tried to put it out with CO₂ and then water from a nearby fire station. Since the two crew members did not don OBAs (oxygen breathing apparatus), they were forced to abandon their effort quickly because of dense, white smoke. The ship has been at general quarters for approximately 5 minutes.

Phone Talkers

*Damage Control Central
(the control station)*

Repair Locker Two

Repair Locker Three

Repair Locker Five

Station

Transmission

DC Central: All Stations – Central. Phone check.

Repair Two: Repair Too, aye.

Repair Five: Repair Fife, aye.

DC Central: Repair Tree – Central. Phone check.

Repair Three: Repair Tree, aye. I read you very weak. I think I have defective phones. Request permission to go off the line to change phones.

<u>Station</u>	<u>Transmission</u>
<i>DC Central:</i>	Central – Repair Tree. Go off the line to change your phones.
<i>Repair Three:</i>	Going off the line to change phones. Repair Tree, aye.
<i>DC Central:</i>	Repair Too, Repair Fife – Central. Report status of condition Zebra and manned and ready.
<i>Repair No:</i>	Report status of Zebra and manned and ready. Repair Too, aye. Manned and ready. Zebra is set in Repair Too.
<i>Repair Five:</i>	Report status of Zebra and manned and ready. Repair Fife, aye. Manned and ready. Zebra is not set in Repair Fife.
<i>DC Central:</i>	Repair Too, Repair Fife, manned and ready; Zebra set in Repair Too; Zebra is not set in Repair Fife. Central, aye. Repair Fife, notify Central when Zebra is set in Repair Fife.
<i>Repair Five:</i>	Notify Central when Zebra is set in Repair Fife. Repair Fife, aye.
<i>Repair Three:</i>	Central – Repair Tree. Back on the line. How do you read me?
<i>DC Central:</i>	Repair Tree – Central. I read you loud and clear. Report status of Zebra and manned and ready in Repair Tree.
<i>Repair Three:</i>	Report status of Zebra and manned and ready. Repair Tree, aye. Standby.

<u>Station</u>	<u>Transmission</u>
<i>Repair Two:</i>	Central – Repair Too, Primary fire boundary forward is set at frame wun zero zero. Secondary fire boundary forward is set at frame niner zero. Primary fire boundary aft is set at frame wun too zero. Secondary fire boundary aft is set at frame wun tree zero. Also be advised investigators report heavy, white smoke in and around compartment wun tack wun wun six tack wun tack LEE mah, operations passageway.
<i>DC Central:</i>	Fire boundaries set. Primary forward frame wun zero zero. Secondary forward frame niner zero. Primary aft frame wun too zero. Secondary aft frame wun tree zero. Understand investigators report heavy, white smoke in and around compartment wun tack wun wun six tack wun tack LEE mah, operations passage way. Central, aye.
<i>Repair Three:</i>	Central – Repair Tree. Repair Tree manned and ready. Zebra is set.
<i>DC Central:</i>	Manned and ready. Zebra set in Repair Tree. Central, aye.
<i>Repair Five:</i>	Central – Repair Fife. Zebra is set in Repair Fife.
<i>DC Central:</i>	Zebra is set in Repair Fife. Central, aye. Repair Tree, Repair Fife – Central. Have your fire teams standing by to assist Repair Too with class AL fah fire in compartment wun tack wun wun six tack zero tack LEE mah, operations berthing.

<u>Station</u>	<u>Transmission</u>
<i>Repair Three:</i>	Have fire team standing by to assist Repair Too with class AL fah fire in compartment wun tack wun wun six tack zero tack LEE mah, operations berthing. Repair Tree, aye.
<i>Repair Five:</i>	Have fire team standing by to assist Repair Too with class AL fah fire in compartment wun tack wun wun six tack zero tack LEE mah, operations berthing. Repair Fife, aye.
<i>Repair Two:</i>	Central – Repair Too. Electrical power is secured in compartment wun tack wun wun six tack zero tack LEE mah.
<i>DC Central:</i>	Electrical power is secured in compartment wun tack wun wun six tack zero tack LEE mah. Central, aye.
<i>Repair Two:</i>	Central – Repair Too. Request permission for fire party to enter compartment wun tack wun wun six tack zero tack LEE mah to fight class AL fah fire. Standby by for fire party members names and OBA start time.
<i>DC Central:</i>	Repair Too – Central. Enter compartment wun tack wun wun six tack zero tack LEE mah to fight class AL fah fire when ready. Pass fire party members names and the OBA start time.
<i>Repair Two:</i>	Enter compartment wun tack wun wun six tack zero tack LEE mah to fight class AL fah fire when ready. Repair Too, aye, Central – Repair Too. Names of fire party members entering space to follow: DC2 Frost, DC3 Boat, GMG3 Doe, SM3 Pistol, ENFN Brush, SK3 Seaman, FN Christmas, and SN Door. OBA start time zero ate fo-wer niner.

<u>Station</u>	<u>Transmission</u>
<i>DC Central:</i>	Names of fire party members entering space to follow: DC2 Frost, DC3 Boat, GMG3 Doe, SM3 Pistol, ENFN Brush, SK3 Seaman, FN Christmas, and SN Door. OBA start time zero ate fo-wer niner. Central, aye. Say again name of GMG3; is name Doe or Door?
<i>Repair Two:</i>	Central – Repair Too. I say again: Doe. I spell: DELL ta OSS cah ECH oh. Doe.
<i>DC Central:</i>	DELL ta OSS cah ECH oh. Doe. Central, aye.
<i>Repair Two:</i>	Central – Repair Too. Fire party has entered compartment wun tack wun wun six tack zero tack LEE mah through quick-acting, watertight door wun tack wun wun six tack too tack LEE mah to fight class AL fah fire.
<i>DC Central:</i>	Fire party has entered compartment wun tack wun wun six tack zero tack LEE mah through quick-acting, watertight door wun tack wun wun six tack too tack LEE mah to fight class AL fah fire. Central, aye.
<i>Repair Two:</i>	Central – Repair Too. Class AL fah fire in compartment wun tack wun wun six tack zero tack LEE mah is under control.
<i>DC Central:</i>	Class AL fah fire in compartment wun tack wun wun six tack zero tack LEE mah is under control. Central, aye.

<u>Station</u>	<u>Transmission</u>
<i>Repair Two:</i>	Central – Repair Too. Class AL fah fire in compartment wun tack wun wun six tack zero tack LEE mah is out. Reflash watch set by SM3 Pistol and ENFN Brush. Cause of class AL fah fire is unknown at this time.
<i>DC Central:</i>	Class AL fah fire in compartment wun tack wun wun six tack zero tack LEE mah is out. Reflash watch set by SM3 Pistol and ENFN Brush. Cause of class AL fah fire is unknown at this time. Central, aye.
<i>Repair Two:</i>	Central – Repair Too. Request too portable electric blowers to assist in desmoking compartment wun tack wun wun six tack zero tack LEE mah.
<i>DC Central:</i>	Request too portable electric blowers to assist in desmoking compartment wun tack wun wun six tack zero tack LEE mah. Central, aye.
<i>DC Central:</i>	Repair Fife – Central. Send too portable electric blowers to Repair Too.
<i>Repair Five:</i>	Send too portable electric blowers to Repair Too. Repair Fife, aye.
<i>Repair Two:</i>	Central – Repair Too. Desmoking and overhauling are in progress.
<i>DC Central:</i>	Desmoking and overhauling are in progress. Central, aye.
<i>Repair Two:</i>	Central – Repair Too. Request an oxygen indicator be sent to Repair Too.
<i>DC Central:</i>	Request oxygen indicator be sent to Repair Too. Central, aye.

<u>Station</u>	<u>Transmission</u>
<i>DC Central:</i>	Repair Tree – Central. Send an oxygen indicator to Repair Too.
<i>Repair Three:</i>	Central – Repair Tree. Say again.
<i>DC Central:</i>	Repair Tree – Central. I say again: Send an oxygen indicator to Repair Too.
<i>Repair Three:</i>	Send an oxygen indicator to Repair Too. Repair Tree, aye.
<i>DC Central:</i>	Repair Too – Central. Report the status of desmoking and overhaul of class AL fah fire.
<i>Repair Two:</i>	Report status of desmoking and overhaul of class AL fah fire. Repair Too, aye. Desmoking seven zero percent complete. Overhaul fife zero percent complete,
<i>DC Central:</i>	Desmoking fife zero percent complete. Overhaul seven zero percent complete. Central, aye.
<i>Repair Two:</i>	Central – Repair Too. Negative. I say again: Desmoking seven zero percent complete. Overhaul fife zero percent complete.
<i>DC Central:</i>	Desmoking seven zero percent complete. Overhaul fife zero percent complete. Central, aye.
<i>Repair Two:</i>	Central – Repair Too. Electrical power in compartment wun tack wun wun six tack zero tack LEE mah cannot be restored because of damaged wiring. Estimated time of repair ate hours. Rigging additional emergency lighting in the space.

<u>Station</u>	<u>Transmission</u>
<i>DC Central:</i>	Electrical power in compartment won tack won won six tack zero tack LEE mah cannot be restored due to damaged wiring. Estimated time of repair ate hours. Rigging additional emergency lighting in the space. Central, aye.
<i>Repair Two:</i>	Central – Repair Too. Desmoking completed, Overhaul seven fife percent complete. Ventilation has been restored. Results of oxygen test: too won point fife percent oxygen in space. Negative explosive gases in space.
<i>DC Central:</i>	Desmoking completed. Overhaul seven fife percent complete. Ventilation has been restored. Results of oxygen test: too won point fife percent oxygen in space. Negative explosive gases in space. Central, aye.
<i>DC Central:</i>	All Stations – Central. Set material condition Yoke.
<i>Repair Two:</i>	Set material condition Yoke. Repair Too, aye.
<i>Repair Three:</i>	Set material condition Yoke. Repair Tree, aye.
<i>Repair Five:</i>	Set material condition Yoke. Repair Fife, aye.
<i>Repair Two:</i>	Central – Repair Too. Overhaul of class AL fah fire in operations berthing is complete.
<i>DC Central:</i>	Overhaul of class AL fah fire in operations berthing is complete. Central, aye.
<i>Repair Three:</i>	Central – Repair Tree. Material condition Yoke is set in Repair Tree.
<i>DC Central:</i>	Material condition Yoke is set in Repair Tree. Central, aye.

<u>Station</u>	<u>Transmission</u>
<i>Repair Two:</i>	Central – Repair Too. Material condition Yoke is set in Repair Too.
<i>DC Central:</i>	Material condition Yoke is set in Repair Too, Central, aye.
<i>Repair Five:</i>	Central – Repair Fife. Material condition Yoke is set in Repair Fife.
<i>DC Central:</i>	Material condition Yoke is set in Repair Fife. Central, aye.
<i>DC Central:</i>	All Stations – Central. Secure from general quarters.
<i>Repair Two:</i>	Secure from general quarters. Repair Too, aye. Going off the line.
<i>Repair Three:</i>	Secure from general quarters. Repair Tree, aye. Going off the line.
<i>Repair Five:</i>	Secure from general quarters. Repair Fife, aye. Going off the line.
<i>DC Central:</i>	All Stations – Central. Going off the line.

LOOKOUT EXERCISE

Scenario

The ship is en route from Naval Station Mayport, Florida, to Naval Station Guantanamo Bay, Cuba, to conduct a month of refresher training. The ship has been under way for 34 hours and is currently transiting through the windward passage on course 170 True at 15 knots. The windward passage is located in the Bahama Islands chain. The passage is used regularly by ships

transiting to and from the Caribbean and North and South America. The time of day is 0830 (local).

Phone Talkers

*Combat Information Center (CIC)
(the control station)*

Bridge

Forward (Fwd) Lookout

After (Aft) Lookout

<u>Station</u>	<u>Transmission</u>
<i>CIC:</i>	Bridge – CIC. Surface contact designated skunk pah PAH. Bearing wun seven zero, range wun fife thousand yards, on course tree tree too, speed ate knots. CPA [<i>closest point of approach</i>] zero six fife, fife thousand yards at time zero niner zero fo-wer.
<i>Bridge:</i>	Surface contact designated skunk pah PAH, Bearing wun seven zero, range wun fife thousand yards, on course tree tree too, speed ate knots. CPA zero six fife, fife thousand yards at time zero niner zero fo-wer. Bridge, aye.
<i>CIC:</i>	Forward Lookout – CIC. Do you have a visual on a surface contact between tree fife zero and zero zero fife on the horizon?
<i>Fwd Lookout:</i>	CIC – Forward Lookout. Negative. I have no contacts between tree fife zero and zero zero fife. I still have the sailboat, now bearing zero niner zero on the horizon, and the large merchant now bearing too niner fife. No other contacts at this time.

<u>Station</u>	<u>Transmission</u>
<i>CIC:</i>	No contact between tree fife zero and zero zero fife. You still have the sailboat now bearing zero niner zero and the large merchant now bearing too niner fife. CIC, aye. Continue looking for a surface contact between tree fife zero and zero zero fife.
<i>Fwd Lookout:</i>	Continue looking for a surface contact between tree fife zero and zero zero fife. Forward Lookout, aye.
<i>Aft Lookout:</i>	CIC – Aft Lookout. Air contact bearing wun six fife, position angle twenty, moving left to right slowly.
<i>CIC:</i>	Air contact bearing wun six fife, position angle twenty, moving left to right slowly. CIC, aye. Can you identify the aircraft?
<i>Aft Lookout:</i>	CIC – Aft Lookout. Affirmative. The aircraft is a small, twin-engine prop plane.
<i>CIC:</i>	Aircraft is a small, twin-engine prop plane. CIC, aye.
<i>Bridge:</i>	Aft Lookout – Bridge. Can you read the side number on the aircraft?
<i>Aft Lookout:</i>	Bridge – Aft Lookout. Affirmative. Number is: no VEM ber AL fah LEE mah too six ate wun tree zero niner.
<i>Bridge:</i>	Number is no VEM ber AL fah LEE mah too six ate wun tree zero niner. Bridge, aye.
<i>Fwd Lookout:</i>	CIC – Forward Lookout. Surface contact bearing tree fife – <i>Fwd lookout interrupted by aft lookout</i>

<u>Station</u>	<u>Transmission</u>
<i>Aft Lookout:</i>	Bridge – Aft Lookout. Is my relief on the –
<i>CIC:</i>	Silence on the line! Forward Lookout make your report.
<i>Fwd Lookout:</i>	CIC – Forward Lookout. Surface contact bearing tree fife fife on the horizon. Appears to be some type of fishing boat.
<i>CIC:</i>	Surface contact bearing tree fife fife on the horizon. Appears to be some type of fishing boat. CIC, aye. Forward Lookout, can you determine the target angle of the vessel?
<i>Fwd Lookout:</i>	CIC – Forward Lookout. Affirmative. Target angle is zero too zero.
<i>CIC:</i>	Target angle is zero too zero. CIC, aye. Bridge – CIC. Update on skunk pah PAH. Revised course and speed tree tree ate at six knots. Revised CPA zero fife fife, tree thousand yards, at time zero niner wun seven.
<i>Bridge:</i>	Course and speed tree tree ate at six knots. CPA zero fife fife, tree thousand yards, at time zero niner wun seven. Bridge, aye.
<i>Aft Lookout:</i>	CIC – Aft Lookout. Request permission to go off the line to change phone talkers.
<i>CIC:</i>	Aft Lookout – CIC. Go off the line to change phone talkers.
<i>Aft Lookout:</i>	Going off the line to change phone talkers. Aft Lookout, aye.
<i>Aft Lookout:</i>	CIC – Aft Lookout. Back on the line.

<u>Station</u>	<u>Transmission</u>
<i>CIC:</i>	Aft Lookout back on the line. CIC, aye.
<i>Fwd Lookout:</i>	CIC – Forward Lookout. Helicopter bearing tree five zero, position angle ten, moving from left to right.
<i>CIC:</i>	Helicopter bearing tree five zero, position angle ten, moving from left to right. CIC, aye
<i>Bridge:</i>	CIC – Bridge. The helicopter is a U.S. Coast Guard SH3; that's see AIR rah hoh TELL tree.
<i>CIC:</i>	The helicopter is a U.S. Coast Guard see AIR rah hoh TELL tree. CIC, aye.
<i>Fwd Lookout:</i>	<i>CIC</i> – Fwd Lookout. Small fishing boat bearing zero zero zero, estimated range six thousand yards.
<i>CIC:</i>	Small fishing boat bearing zero zero zero, estimated range six thousand yards. CIC, aye. Good job Forward Lookout. CIC does not hold the contact on radar.
<i>Bridge:</i>	CIC – Bridge. Changing course to wun five zero to avoid small fishing boat bearing wun seven zero.
<i>CIC:</i>	Changing course to wun five zero to avoid small fishing boat bearing wun seven zero. CIC, aye. Bridge–CIC. New contact designated skunk kay BECK bearing wun seven zero, estimated range six thousand yards. Identified by Forward Lookout as small fishing boat. CIC does not hold contact on radar.

<u>Station</u>	<u>Transmission</u>
<i>Bridge:</i>	Skunk kay BECK bearing wun seven zero, estimated range six thousand yards. Identified by Forward Lookout as small fishing boat. CIC does not hold contact on radar. Bridge, aye. CIC — Bridge. Bridge has a good visual on skunk kay BECK. Vessel is a very small wooden boat with too people on board. Vessel now has a good right-bearing drift. Intend to return to base course wun seven zero when skunk kay BECK CPA's on the starboard beam.
<i>CIC:</i>	Vessel is a very small wooden boat with too people on board. Vessel has a good right-bearing drift. Intend to return to base course wun seven zero when skunk kay BECK CPA's on the starboard beam, CIC, aye.
<i>Fwd Lookout:</i>	CIC – Forward Lookout. Lighthouse in the horizon bearing tree fife fife. I can also see a radio tower bearing tree fo-wer fife.
<i>CIC:</i>	Lighthouse bearing tree fife fife. Also a radio tower bearing tree fo-wer fife. CIC, aye. Forward Lookout – CIC. Lighthouse and radio tower are on San Salvador Island. Report as soon as you see landfall.
<i>Fwd Lookout:</i>	Lighthouse and radio tower are on San Salvador Island. Report as soon as I can see landfall. Forward Lookout, aye.
<i>Bridge:</i>	CIC – Bridge. Change course to wun seven fife.
<i>CIC:</i>	Change course to wun seven fife. CIC, aye.

<u>Station</u>	<u>Transmission</u>
<i>Fwd Lookout:</i>	CIC – Forward Lookout. Landfall sighted, bearing tree fo-wer zero. I can also see too other towers.
<i>CIC:</i>	Landfall sighted, bearing tree fo-wer zero. You can also see too other towers. CIC, aye.
<i>Fwd Lookout:</i>	CIC – Forward Lookout. Request permission to go off the line to change phone talkers.
<i>CIC:</i>	Forward Lookout – CIC. Go off the line to change phone talkers.
<i>Fwd Lookout:</i>	Going off the line to change phone talkers. Forward Lookout, aye.
<i>Aft Lookout:</i>	CIC – Aft Lookout. Small vessel bearing wun wun fife, estimated range too thousand yards.
<i>CIC:</i>	Small boat bearing wun wun fife, estimated range too thousand yards. CIC, tiye. Aft Lookout – CIC. The small boat is skunk kay BECK.
<i>Aft Lookout:</i>	The small boat is skunk kay BECK. Aft Lookout, aye.
<i>Fwd Lookout:</i>	CIC – Forward Lookout. Back on the Line.
<i>CIC:</i>	Forward Lookout– Back on the line. CIC, aye. Bridge – CIC. Surface contact designated skunk ROW me oh bearing wun six fife, range wun niner ate hundred yards, on course tree fife six, speed twelve knots. CPA zero ate tree, ate thousand yards at time ten zero seven.

<u>Station</u>	<u>Transmission</u>
<i>Bridge:</i>	Skunk ROW me oh bearing wun six fife, range wun niner ate hundred yards, on course tree fife six, speed twelve knots. CPA zero ate tree, ate thousand yards at time ten zero seven. Bridge, aye.
<i>CIC:</i>	Forward Lookout – CIC. Look for a surface contact between tree fo-wer fife and zero zero zero. You should see it very soon; it looks like a very large contact on radar.
<i>Fwd Lookout:</i>	Look for a surface contact between tree fo-wer fife and zero zero zero. Forward Lookout, aye.
<i>CIC:</i>	Bridge – CIC. Request permission to scrub skunks no VEM ber and OSS cah. They are off the radar scope.
<i>Bridge:</i>	CIC – Bridge. Scrub skunks no VEM ber and OSS cah.
<i>CIC:</i>	Scrub skunks no VEM ber and OSS cah. CIC, aye. Bridge – CIC. Request permission to put a watch on skunks pah PAH and kay BECK; they are both past CPA and opening.
<i>Bridge:</i>	CIC – Bridge. Put a watch on skunks pah PAH and kay BECK.
<i>CIC:</i>	Put a watch on skunks pah PAH and kay BECK. CIC, aye.
<i>Fwd Lookout:</i>	CIC – Forward Lookout. Surface contact bearing tree fife fife on the horizon. Estimate target angle zero wun zero. Looks like a very large container ship.

<u>Station</u>	<u>Transmission</u>
<i>CIC:</i>	Surface contact bearing tree five five on the horizon. Estimate target angle zero wun zero. Looks like a very large container ship. CIC, aye.
<i>Bridge:</i>	CIC – Bridge. Bridge does not concur with CPA of ROW me oh. Bridge has CPA of zero seven too at fo-WER six five zero yards. Request you recheck your CPA.
<i>CIC:</i>	Bridge does not concur with CPA of ROW me oh. Bridge has CPA of zero seven too at fo-WER six five zero yards. Recheck CPA. CIC, aye.
<i>Fwd Lookout:</i>	CIC – Forward Lookout. It looks like the container ship has changed course to starboard; target angle is now tree five zero.
<i>CIC:</i>	Container ship has changed course to starboard; target angle is now tree five zero. CIC, aye. Bridge – CIC, Revised CPA on ROW me oh zero seven zero at fo-WER six zero zero yards.
<i>Bridge:</i>	Revised CPA on ROW me oh zero seven zero at fo-WER six zero zero yards. Bridge, aye.
<i>CIC:</i>	All Stations – CIC. CIC going off the line to change phone talkers.
<i>Bridge:</i>	Bridge, aye.
<i>Fwd Lookout:</i>	Forward Lookout, aye
<i>Aft Lookout:</i>	Aft Lookout, aye.
<i>CIC:</i>	All Stations – CIC. Back on the line.

<u>Station</u>	<u>Transmission</u>
<i>Bridge:</i>	CIC back on the line. Bridge, aye.
<i>Fwd Lookout:</i>	CIC back on the line. Forward Lookout, aye.
<i>Aft Look-out:</i>	CIC back on the line. Aft Lookout, aye.
<i>Bridge:</i>	CIC – Bridge. Bridge concurs with revised CPA of ROW me oh.
<i>CIC:</i>	Bridge concurs with revised CPA of ROW me oh. CIC, aye.
<i>Bridge:</i>	All Stations – Bridge. Back on the line.
<i>CIC:</i>	Bridge – CIC. What is your name?
<i>Bridge:</i>	SA Boat.
<i>CIC:</i>	Bridge – CIC. Who did you relieve
<i>Bridge:</i>	SN Door.
<i>CIC:</i>	Bridge – CIC. Where is SN Door now?
<i>Bridge:</i>	He is the messenger of the watch.
<i>CIC:</i>	Bridge – CIC. Pass to SN Door: Always notify CIC before going off the line to change phone talkers.
<i>Bridge:</i>	Pass to SN Door: Always notify CIC before going off the line to change phone talkers. Bridge, aye.

SUMMARY

The two exercises in this manual are basic scenarios. Use these exercises in training as suggested in the beginning of this

chapter. These exercises and any that you create and tailor to your particular command will enhance sound-powered phone talker training. A proficient sound-powered telephone talker team is vital to the safety of the ship and crew. You can clearly see how important the sound-powered phone talker is as part of the ship's operating team.

APPENDIX I

REFERENCES USED TO DEVELOP THIS TRAMAN

Chapter 1

Basic Military Requirements, NAVEDTRA 12043, Naval Education and Training Program Management Support Activity, Pensacola, FL, 1992.

Chapter 2

Basic Military Requirements, NAVEDTRA 12043, Naval Education and Training Program Management Support Activity, Pensacola, FL, 1992.

Chapter 3

IC Electrician 3, NAVEDTRA 10559-A, Naval Education and Training Program Management Support Activity, Pensacola, FL, 1989.

Chapter 4

Naval Ships' Technical Manual (NSTM), NAVSEA S9086-PA-STM-000, Chapter 430, "Interior Communication Installations," Naval Sea Systems Command, Washington, DC, 1980.

*U.S. Government Printing Office: 1995 — 633-358/17339

Assignment Questions

Information: The text pages that you are to study are provided at the beginning of the assignment questions.

ASSIGNMENT 1

Textbook Assignment: *Sound-Powered Telephone Talkers' Training Manual*, chapters 1 through 4, pages 1-1 through 3-12.

- 1-1. The sound-powered telephone system uses, which of the following sources?
1. Dry cell batteries
 2. The sound pressure of your voice
 3. Rechargeable battery packs
 4. The ship's electrical power
- 1-2. The mouthpiece and earpiece can be used inter-changeably.
1. True
 2. False
- 1-3. How do you produce enough current to carry your voice to all other stations on the circuit?
1. Speak in a strong clear voice
 2. Make sure the batteries are charged
 3. Adjust the volume control on the amplifier
 4. Speak very loud to vibrate the diaphragm, then speak normally
- 1-4. Which of the following statements describes why receiving accurate up-to-date information on board a ship is so important?
1. Correct and timely data are necessary if the ship is to function properly and achieve its mission
 2. Everyone on board the ship needs to be aware of what is happening
 3. Lack of good communications always causes damage and injury
 4. A record of every evolution must be maintained
- 1-5. What is the correct way to transmit a message the originator has given you?
1. Send only the important parts of the message
 2. Transmit the message exactly as it is given to you
 3. First rephrase the message so everyone on the circuit will understand it
 4. Send only official messages approved by the commanding officer
- 1-6. What station on a sound-powered phone circuit acts as the monitor for all stations?
1. Control
 2. Battle
 3. Central command
 4. Main control
- 1-7. Which of the following statements describes the reason for frequently testing the phone circuits?
1. You may be unaware of a malfunction somewhere in the circuit and fail to receive an important message
 2. To make sure everyone on the circuit stays alert
 3. Standard shipboard procedures require frequent testing
 4. Only to make sure your phones are working properly
- 1-8. What is the name of the alphabet the Navy has developed to avoid confusing the sounds of certain letters?
1. Standard naval alphabet
 2. The international alphabet
 3. The phonetic alphabet
 4. Standard NATO alphabet

QUESTIONS 1-9 THROUGH 1-11 REFER TO THE PHONETIC ALPHABET.

1-9. What is the word pronunciation for the letter "W"?

1. Whisper
2. Whistle
3. Whisker
4. Whiskey

1-10. What is the word pronunciation for the letter "D"?

1. Delta
2. Doctor
3. Deck
4. Dog

1-11. What is the correct spelling for the standard pronunciation of the numeral two?

1. To
2. Tue
3. Tu
4. Too

1-12. What part of the ship is used as the reference point for relative bearings?

1. The stern
2. The forward mast
3. The bow
4. The port beam

1-13. What is the correct way to report a range of 6,740 yards?

1. Six thousand seven hundred and forty yards
2. Six seven four zero yards
3. Six seven fo-wer zero yards
4. Both 2 and 3 above

1-14. An aircraft is sighted bearing 270° relative, 30° above the horizon. What is the correct way to report the bearing and position angle of the contact?

1. Air contact bearing two hundred and seventy, position angle tree
2. Air contact bearing two seven zero, position angle thirty
3. Both 1 and 2 above
4. Air contact bearing two seven zero, position angle tree zero

1-15. Which of the following statements illustrates why circuit discipline is always maintained?

1. The circuit could overload and short out
2. The circuit would become clogged with private conversation and important messages would be missed
3. Circuit discipline is required by the commanding officer
4. Circuit discipline allows everyone a chance to speak

1-16. Which of the following phrases should you say if it becomes necessary to interrupt another station's transmission?

1. Silence on the line
2. Silence on the circuit
3. Silence on the net
4. All stations silence

1-17. How should you deal with a person on the circuit who insists on useless talking?

1. Tell them to leave the circuit
2. Discuss the problem with them later after everyone is secured
3. Remind the person that the line must be kept clear for official messages
4. Tell the person to keep personal conversation to a minimum so important messages can be passed

- 1-18. A ship is sighted by the forward lookout bearing 340° on the horizon. What is the correct way to report the contact to CIC?
1. CIC-Forward lookout-Surface contact bearing tree forty on the horizon
 2. This is Forward lookout-CIC-I have a surface contact bearing tree fo-wer zero on the horizon
 3. CIC-Forward lookout-Surface contact bearing tree fo-wer zero on the horizon
 4. CIC-Forward lookout-Surface contact bearing tree hundred and forty on the horizon
- 1-19. Always use direct questions instead of statements when communicating on the sound-powered telephone.
1. True
 2. False
- 1-20. A circuit test is NOT concluded until which of the following factors are completed?
1. All stations have reported
 2. All equipment faults have been corrected and all stations have reported
 3. All stations have reported and all equipment problems have been identified
 4. All equipment problems have been corrected
- 1-21. When you phonetically spell a difficult word, what prowords do you say before spelling the word?
1. I will spell
 2. Standby for spelling
 3. Spelling to follow
 4. I spell
- 1-22. After relieving another phone talker at a station, what is the proper report to let everyone know you have rejoined the circuit?
1. Back on the line
 2. Back on the circuit
 3. Back on station
 4. Back on the phones
- 1-23. Which of the following statements is the correct response if a message is not clear to you?
1. Please repeat
 2. Repeat your last
 3. Say again
 4. Say the message again
- 1-24. Which of the following actions do you complete first after receiving a message?
1. Identify yourself
 2. Acknowledge the message
 3. Ask the sender to repeat the message
 4. Repeat the message
- 1-25. When you are sending a message, which of the following actions should you do last?
1. State the message
 2. Call up the station you want to communicate with
 3. Identify your own station
 4. Ask the receiving station to repeat the message
- 1-26. When temporarily leaving the circuit, you do not always have to get permission.
1. True
 2. False
- 1-27. When you are secured from an evolution, which of the following statements describes what you should do with your phones?
1. Phones should be turned in to the IC shop for maintenance until needed again
 2. Leave the phones plugged in at the station, ready for quick access
 3. Properly make up your phones and give them to your DCPO so he or she can stow them
 4. Phones should be correctly made up and stowed in their proper place

- 1-28. How many types of shipboard sound-powered phone circuits are there?
1. Five
 2. Two
 3. Three
 4. Four
- 1-29. If you store cleaning gear in a sound-powered telephone stowage box, what harmful affect could this have on the telephone set?
1. The moisture will cause the rubber to decompose prematurely
 2. The moisture and chemicals will cause the aluminum diaphragms to rapidly oxidize
 3. The moisture could cause a short in the sound-powered telephone wiring
 4. Chemicals are hazardous materials that give off fumes that can be harmful
- 1-30. What is the proper way to store headset-chestsets in machinery spaces?
1. On hooks
 2. Next to the jackbox
 3. In the soundproof phone booth
 4. In stowage boxes
- 1-31. When using standard telephone talker procedures, most messages are divided into how many parts?
1. Five
 2. Two
 3. Three
 4. Four
- 1-32. What is the correct phonetic pronunciation for PAPA?
1. pah PAH
 2. pa pa
 3. PAH pa
 4. Pah pah
- 1-33. What is the correct phonetic pronunciation for YANKEE?
1. YAN key
 2. YANK kee
 3. yang key
 4. YANG key
- 1-34. What is the correct enunciation for the numeral eight?
1. Aight
 2. ATE
 3. Eight
 4. EITE
- 1-35. Bearings are always reported in how many digits?
1. One
 2. Two
 3. Three
 4. Four
- 1-36. Ranges are always reported digit by digit except for what multiples?
1. Hundreds only
 2. Thousands only
 3. Tens and Hundreds
 4. Hundreds and Thousands
- 1-37. What are the three classifications of sound-powered phone circuits?
1. Primary, secondary and auxiliary
 2. Primary, supplementary, and auxiliary
 3. Primary, auxiliary, and emergency
 4. Primary, secondary, and supplementary
- 1-38. Which of the following circuits is used as the lookout circuit?
1. JW
 2. 1JV
 3. JA
 4. JL
- 1-39. Which of the following circuits is used as the maneuvering and docking circuit?
1. 1JV
 2. 1JG
 3. 1JS
 4. 4JV

- 1-40. What letter precedes all auxiliary and supplementary circuit designations?
1. J
 2. Z
 3. X
 4. W
- 1-41. Supplementary circuits are normally identified as what category of circuit?
1. Switchbox
 2. String
 3. Switchboard
 4. Series
- 1-42. Which of the following advantages does the selector switch have over the single circuit jackbox?
1. It enables the control station to monitor all circuits
 2. It allows the phone talker to talk on any one of several circuits by turning the rotary dial
 3. It provides alternate circuits if a malfunction occurs in the circuit
 4. It reduces the amount of single jackboxes necessary when space is limited
- 1-43. What precaution has been taken to protect the auxiliary circuit when damage occurs to the primary circuit?
1. The wiring is wrapped in a special insulation for protection
 2. The wiring is placed as close as possible to the centerline of the ship
 3. The wiring is separated as much as practicable from the primary wiring
 4. The wiring is placed inside kevlar tubes
- 1-44. What does the letter *J* indicate in sound-powered circuit designations?
1. Primary circuits
 2. Supplementary circuits
 3. General purpose
 4. Sound power
- 1-45. Which of the following circuits is the captain's battle circuit?
1. JA
 2. JL
 3. JX
 4. JG
- 1-46. Which of the following *J* circuits is the ship-control bearing circuit?
1. JG
 2. JX
 3. JW
 4. JL
- 1-47. What will happen if you have the earpiece on your headset turned away from your head?
1. The phones will pick up distracting noises
 2. The earpiece transmitter will short out and be useless when you need it
 3. You will damage your hearing if you are in a noisy space
 4. You will not hear important messages
- 1-48. what does the letter *S* indicate in a sound powered circuit designation?
1. Sonar
 2. Sound power
 3. Supplementary
 4. General Purpose
- 1-49. What are the names of the three types of sound-powered telephone circuits?
1. Switchbox, series, and string
 2. Series, switchboard, and string
 3. Parallel, switchbox, and string
 4. String, switchbox, and switchboard

- 1-50. When coiling the sound-powered telephone cord and preparing the headset for stowage, about how many inches across should you make the loops?
1. Eight
 2. Fifteen
 3. Twelve
 4. Ten
- 1-51. Which of the following circuits is a supplementary circuit?
1. 4JZ
 2. 1JV
 3. X1J
 4. X2JZ
- 1-52. Which of the following circuits is an auxiliary circuit?
1. JX
 2. X1JV
 3. X8J
 4. 1JS
- 1-53. What supplementary circuit is used most often?
1. The call signal station
 2. The E call station
 3. The information station
 4. The administrative station
- 1-54. What do the first numerals before a letter indicate in a sound-powered circuit designation?
1. The location of the station on the circuit
 2. The purpose of the circuit
 3. Number stations on the circuit
 4. The circuit classification
- 1-55. What is the most important interior communications system aboard a ship?
1. Ship's telephone system
 2. Pneumatic tube system
 3. Sound-powered telephone system
 4. Voice tube system

